

Emulsifying homogenizing pump series



In-line Mixer





Contents

Pages

✓ **Stursan ST-HC JZ1**

- 4 - 15 -

Technical Specifications

Technical Advantages

Pump Inlet/outlet Connection Standard

Typical applications

Mechanical Seal Features

Model instruction

Selection table

Data sheet

✓ **Stursan ST-HC JZ3**

- 14 - 22 -

Technical Specifications

Technical Advantages

Working schematic diagram

Typical applications

Mechanical Seal Features

Parts component

Model instruction

Selection table

Data sheet



Stursan.com

Catalogue technical information only for reference. Stursan reserves the rights to update and upgrade without prior notice.

10.2020 / Revisión 1

STURSAN



✓ Stursan ST-HC JZ1

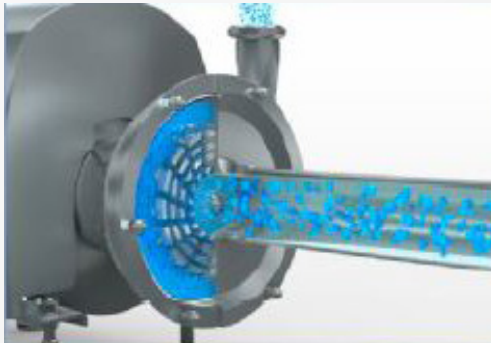

Series single stage emulsifying homogenizing pump

Solutions for high-efficiency, dispersion, cut, refinement, smash, emulsification, mixing, homogenization, high purity.



JZ1 series is emulsifying homogenizing pump that could be operated for continuous production, and is composed of stator and rotor. The processed media will be operated through 6-10 layers stators and rotors, and then be dispersed, cut, refined, smashed, emulsified, mixed etc. step by step. Compared with traditional manufacturing technique, this pump is more easier, convenient and optimized, which has improved production efficiency and promoted media quality. It's mainly used in the industry of food, beverage, pharmacy, health protection, fine, chemistry, coating, pesticide, daily chemical, papermaking, etc.

Technical Specifications

Technical Specifications	
Max. flow rate	40m ³ /h
Max. power	45KW
Max. temperature	-20°C to 140°C
Media refinement	≤ 60 GRIT (≠ 300 μ m)
Material	304 /316L, 1.431/1.4404, ASME BPE 316L,1.4435 NB2 Fe ≤ 0.5%
Surface treatment	≤ Ra0.8 μ m, ≤ Ra0.6 μ m, ≤ Ra0.4 μ m,
Mechanical seal	Single and double mechanical seals
Mechanical seal combination	See configuration table
Inlet/Outlet connection	Thread, clamp, flange, Aseptic flange
Certification	 CE  EC 1935/2004

Technical Advantages

- Maintenance disassembly and installation can be completed without professional staff and special tools.
- Initial use of installation debugging, even if a short reverse rotation will not be damaged.
- Impeller and shaft are connected by keyway; impeller and mechanical seal rotating ring are connected by pin; mechanical seal static ring and pump body are connected by special-shaped flange.
- Compatible with single and double machine seal, only need to change machine seal.



Very simple maintenance, no special tools required, no professionals required.

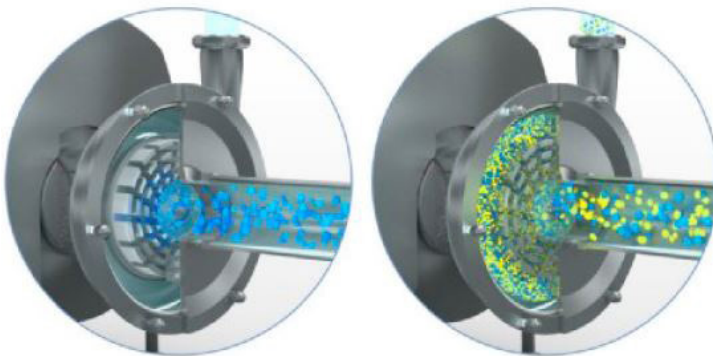

The gap between the stator and the rotor is 0.5mm

Stator

Rotor

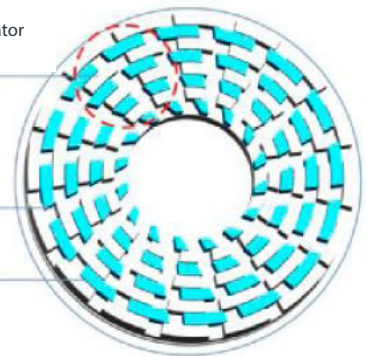



Pump Inlet/outlet Connection Standard



Hand wheel nut



Union nut inlet/outlet



Threaded inlet/outlet



Clamp inlet/outlet



Aseptic Flange (DIN 11864)
Inlet/Outlet



90°...0° inclined outlet



90°...135° inclined outlet

Connection: Thread, Clamp, Flange, Aseptic flange, KF etc.

Standard: DIN SMS ISO IDF RJT ASME BPE 3A I-line



DIN 11851

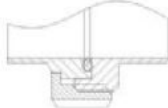

DIN 11864-1-A

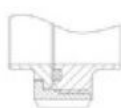

SMS



ISO/IDF

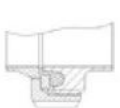

RJT

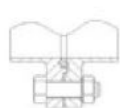

DIN 11864-2

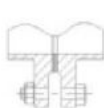

Flange



DIN 11864-3



DIN 32676
ISO 2852



ISO 2861





Typical applications



Food & beverage

Juice, jam, ice cream, dairy products, food additives, tea drinks, chocolate, soymilk, essence



Daily chemical

Liquid detergent, liquid soap, facial cleanser, emulsified silicone oil, fragrance compound, skin care product, cosmetics



Bio-pharmaceutical

Injection, antibiotic, medicine emulsion, medicine emulsifiable paste, health care products, microcapsule emulsification, cell tissue smash, etc



Papermaking

Paper pulp, padding, dry strength agent, wet strength agent, sizing agent, retention and drainage aid, antifoaming agents, coating, water treatment chemicals, etc



Petrochemical industry

Lubricant, heavy oil emulsification, diesel oil emulsification, modified asphalt, catalyzer, wax emulsion, etc. Which media need to be emulsified and homogenized



Fine chemical engineering

Pigment, dyestuff, plastic additive, textile assistant, adhesive, resin emulsification, hot melt adhesive, sealant, glue, sizing agent, finishing agent, surfactant, dye leveller, carbon black dispersion, anti-sticking agent, textile finishing agent, brightener, leather auxiliaries, pigment paste, etc. Which media need to be emulsified and homogenized.



Coating & ink

Printing ink, oil paint, emulsion paint, coating, nanopaint, photocurable coating, coating adhesive, carbon black dispersion, glaze, bentonite, etc



Pesticide

Insecticide, herbicide, pesticide missible oil, fertilizer, inert ingredient, etc. Which media need to be emulsified and homogenized.

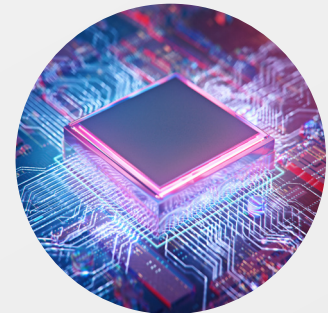

Semiconductor

Dispersion & depolymerization of nanometer materials, etc

Mechanical Seal Features

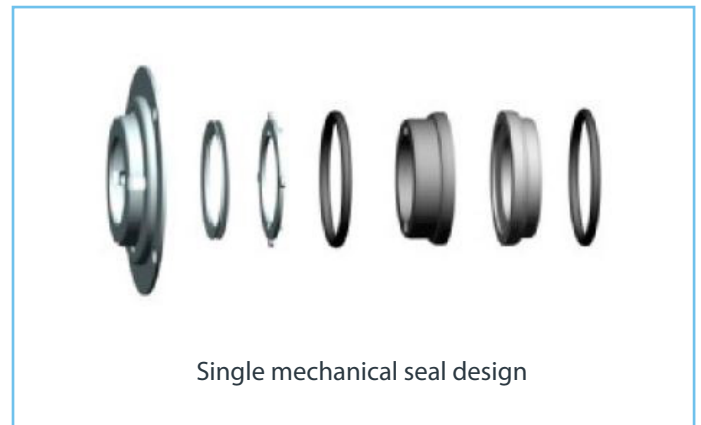
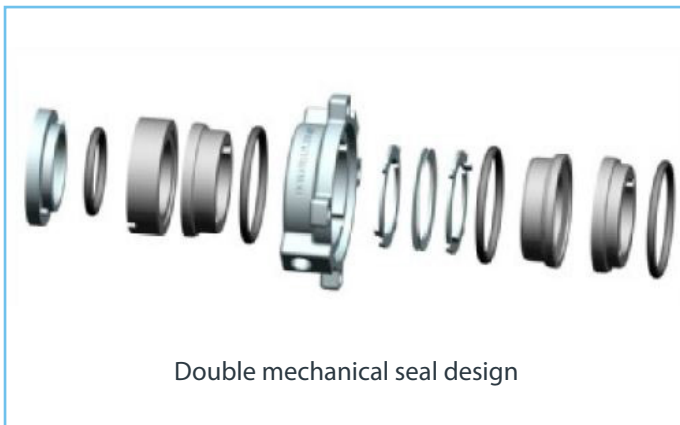
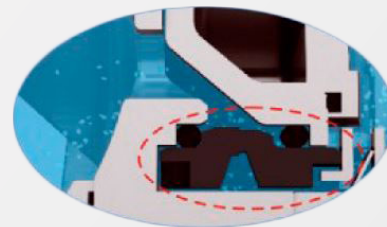
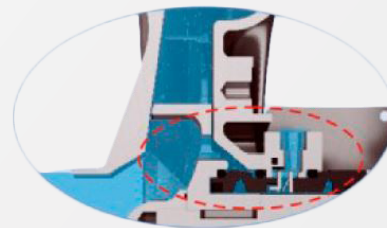
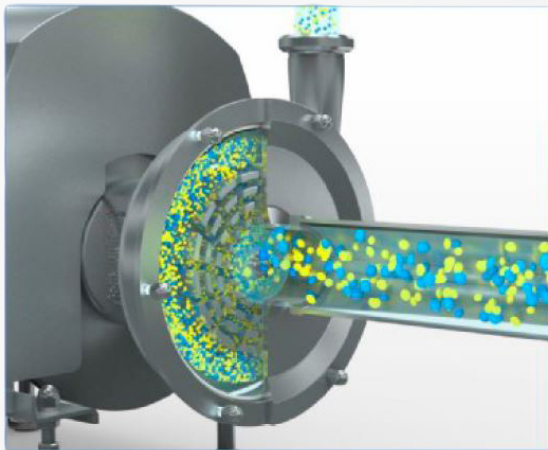

The mechanical seal is designed with pressure balance and super long working life, can be disassembled and maintained easily without special tools. The sanitary purity is according to CE and EC 1935/2004 certifications, and has lots of configuration.

Mechanical Seal Configuration	
Standard	Optional
1. SIC/C/EPDM	2. SIC/C/FKM 3. SIC/C/HNBR 4. SIC/SIC/EPDM 5. SIC/SIC/FKM 6. SIC/ SIC/HNBR 7. TC/TC/EPDM 8. TC/TC/FKM 9. TC/TC/HNBR

Note: Above configurations is suitable for single and double mechanical seal



Very simple maintenance, no special tools required, no professionals required

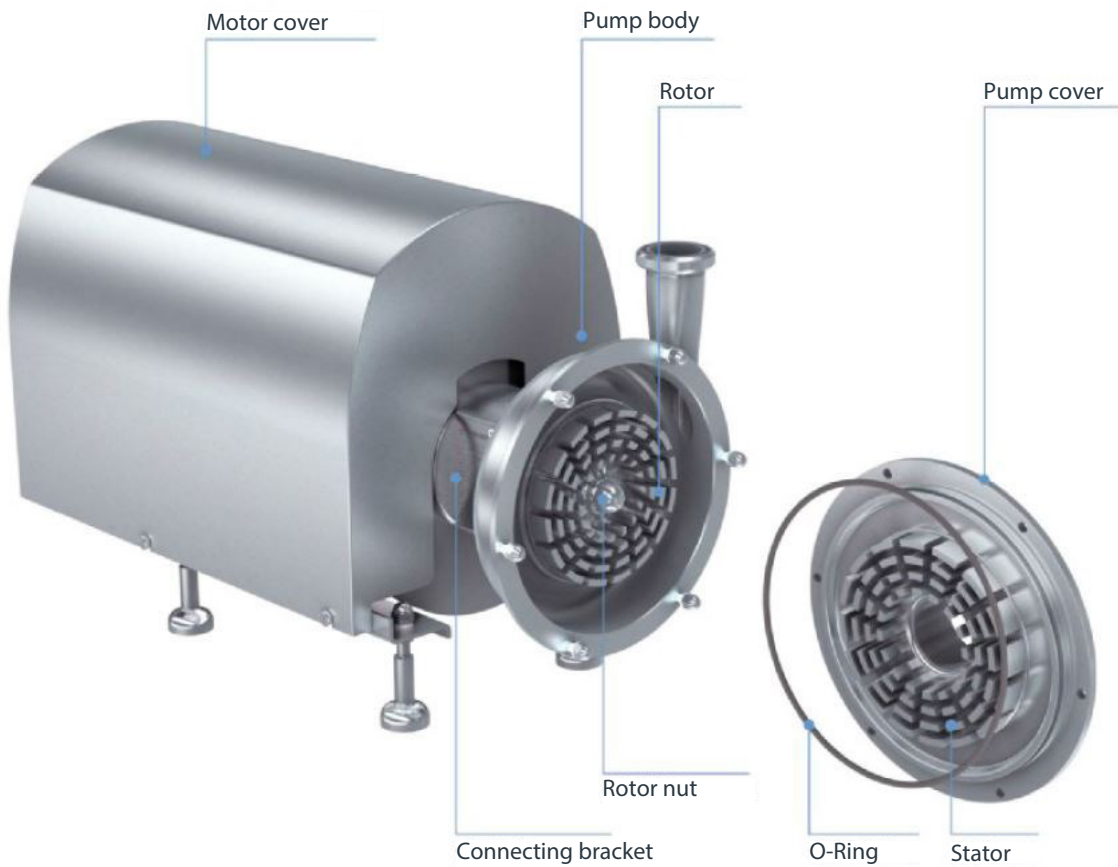

Model Instruction



Stursan ST-HC JZ1 **130** **3T** **10** **3KW** **380V** **50HZ** **M** **1.5/1.5** **S**

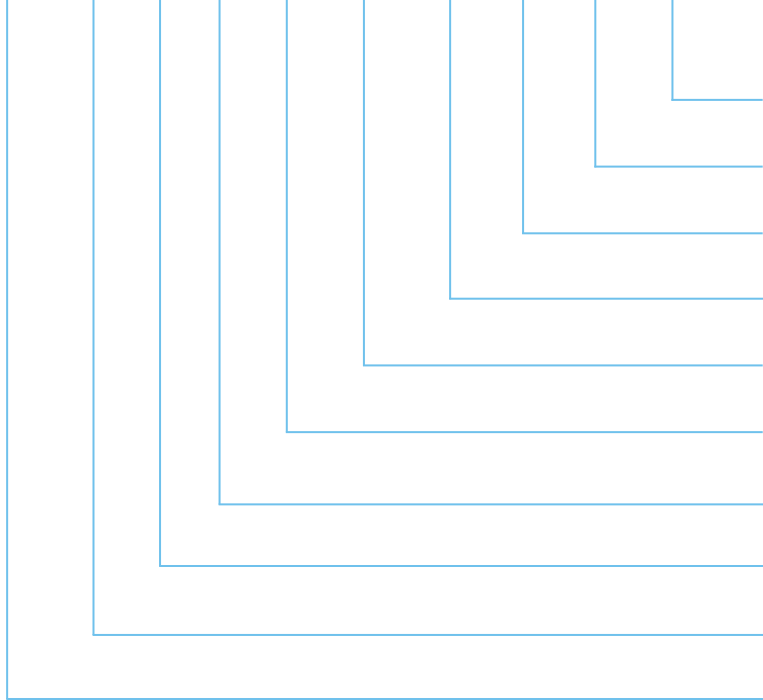

Connection standard: DIN (D) SMS (S) 3A(A) RJT (R) ISO/IDF (I)

Inlet/Outlet size

Connection way: Thread (M) Clamp (C) Flange (F)

Motor frequency: 50HZ; 60HZ

Voltage: 110V 220V 380V (see table)

Motor power: 1.1kw 1.5kw 2.2kw.....

Emulsifying homogenizing pump head (see table)

Emulsifying homogenizing pump flow (see table)

Emulsifying homogenizing pump model

Emulsifying homogenizing pump code: Stursan ST-HC JZ1

For example: Stursan ST-HC JZ1-130-3T-10-3KW-380V-50HZ-M-1.5"/1.5"-S



Selection table



Model	Power (kw)	Flow (m ³ /h)	Outlet pressure (bar)	Rotate speed (r/min)	Inlet/Outlet	Weight (kg)
Stursan ST-HC JZ1-130	3.0	3.0	1.0	2900	1.5"/1.5"	52.0
	4.0		1.0	2900		58.0
	5.5		1.0	2900		74.0
Stursan ST-HC JZ1-150	4.0	6.0	1.5	2900	2"/1.5"	66.0
	5.5		1.5	2900		82.0
	7.5		1.5	2900		93.0
Stursan ST-HC JZ1-170	5.5	10.0	1.5	2900	2.5"/2"	91.0
	7.5		1.5	2900		102.0
	11.0		1.5	2900		144.0
Stursan ST-HC JZ1-190	7.5	15.0	1.5	2900	2.5"/2"	107.0
	11.0		1.5	2900		149.0
	15.0		1.5	2900		164.0
Stursan ST-HC JZ1-210	11.0	25.0	1.5	2900	3"/2.5"	166.6
	15.0		1.5	2900		181.6
	18.5		1.5	2900		211.6
Stursan ST-HC JZ1-240	15.0	40.0	1.5	2900	3"/2.5"	167.0
	18.5		1.5	2900		182.0
	22.0		1.5	2900		212.0

Data Sheet

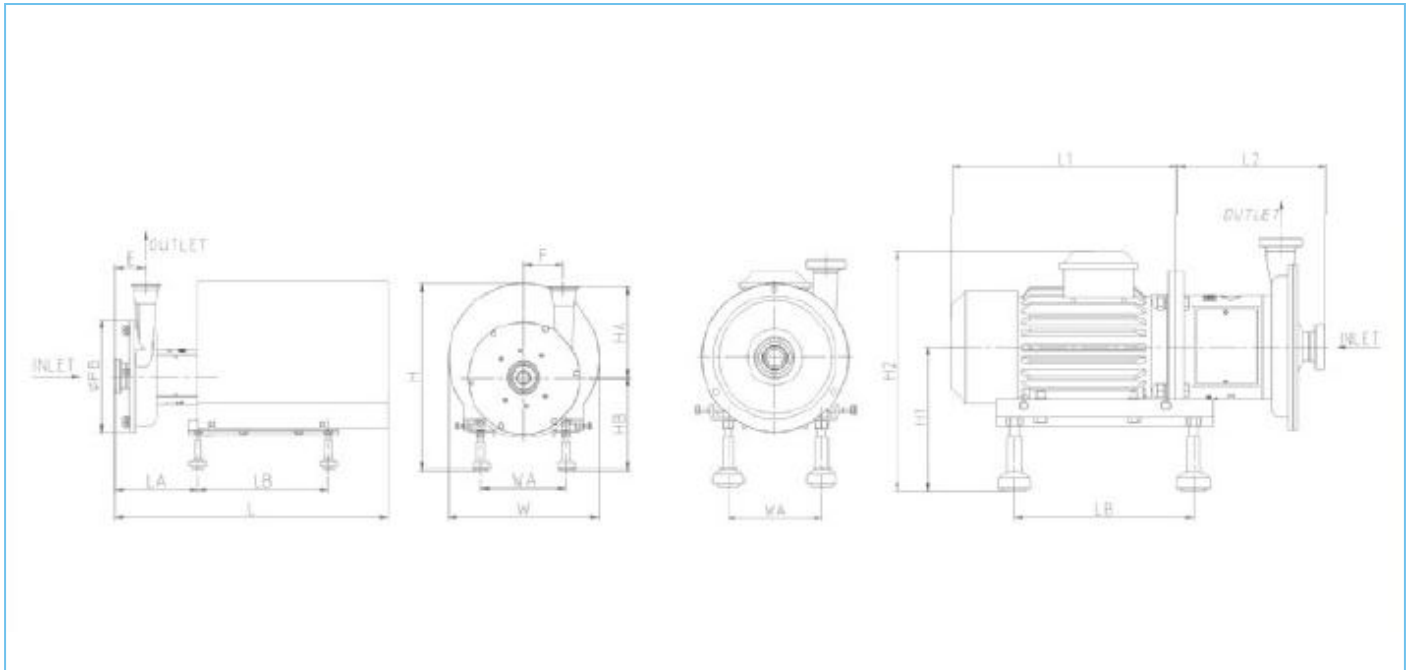

Model	Power (kw)	Inlet	Outlet	PB	F	LB	H	HB	HC	W	WA	L1	H2	SMS				INCH				DIN			
														Thread				Clamp				Thread			
														E	LA	HA	L	E	LA	HA	L	E	LA	HA	L
Stursan ST-HC JZ1-130	3.0	1.5"	1.5"	220	76.5	300	413	218	94.8	320	160	316	333.8	59	158	146	583	52	150	139	576	59	158	146	583
	4.0			220	76.5	300	421	210	94.8	340	190	351	350.8	59	165	146	584	52	157	139	577	59	165	146	584
	5.5			220	76.5	330	466	231	94.8	380	216	399	399.8	59	174	146	654	52	166	139	647	59	174	146	654
Stursan ST-HC JZ1-150	4.0	2"	1.5"	266	98	300	421	210	94.8	340	190	351	350.8	66	164	160	584	59	156	153	577	67	164.5	160	585
	5.5-7.5			266	98	330	466	231	94.8	380	216	399	399.8	66	173	160	654	59	165	153	647	67	173.5	160	655
Stursan ST-HC JZ1-170	5.5-7.5	2.5"	2"	282	100.5	330	466	231	94.8	380	216	399	399.8	77.5	210	200	689	66	199	193	677	76.5	209	201	688
	11			282	100.5	450	551	260	94.8	470	254	576.5	511.8	77.5	193	200	767	66	181	193	755	76.5	191.5	201	766
Stursan ST-HC JZ1-190	7.5	2.5"	2"	328	127.5	330	466	231	94.8	380	216	399	399.8	72.5	207	210	686	61	196	203	674	71.5	206	210	685
	11-15			328	127.5	450	551	260	94.8	470	254	576.5	511.8	72.5	190	210	764	61	178	203	752	71.5	188.5	210	763
Stursan ST-HC JZ1-210	11-15	3"	2.5"	360	141	450	551	260	94.8	470	254	576.5	512.8	74.5	227	235	801	63	215	223	789	73.5	225.5	235	800
	18.5			360	141	450	551	260	94.8	470	254	576.5	512.8	74.5	227	235	801	63	215	223	789	73.5	225.5	235	800
Stursan ST-HC JZ1-240	15-18.5	3"	2.5"	360	141	450	551	260	94.8	470	254	576.5	512.8	74.5	227	235	801	63	215	223	789	73.5	225.5	235	800
	22			360	141	515	583	281	94.8	510	279	573	533.8	74.5	227	235	896	63	215	223	884	73.5	225.5	235	895

Note: The relevant dimensions of the above data diagrams are not regarded as the final basis of the actual object. Stursan keep the right to update the data without further notice.



✓ Stursan ST-HC JZ3

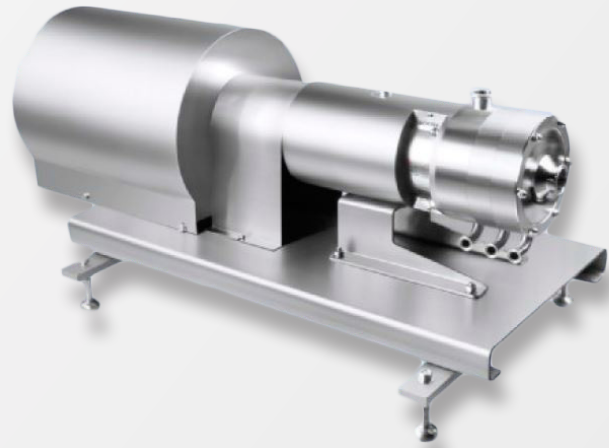
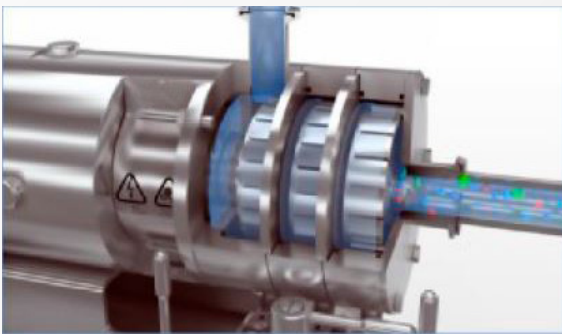

Series multi-stage emulsifying homogenizing pump

High-efficiency, dispersion, cut, refinement, smash, emulsification, mixing, homogenization, high purity solution



Jz3 series is online continuity production emulsification homogeneous pump, and is composed by stators and rotors, processed materials will be stepwise dispersed, sheared, refined, crushed, emulsified, mixed and homogenized through three grades twelve-tier stators and rotors, and then be dispersed, cut, refined, smashed, emulsified, mixed, etc. step by step. Compared with traditional manufacturing technique, this pump is more easier, convenient and optimized, which has improved production efficiency and promoted media quality. It's mainly used in the industry of food, beverage, pharmacy, health protection, fine, chemistry, coating, pesticide, daily chemical, papermaking, etc.

Technical Specifications

Technical Specifications	
Max. flow rate	50m ³ /h
Max. power	90KW
Max. temperature	-20°C to 140°C
Media refinement	≤ 100 GRIT (≠ 200 μ m)
Material	304 /316L, 1.431/1.4404, ASME BPE 316L, 1.4435 NB2 Fe ≤ 0.5%
Surface treatment	≤ Ra0.8 μ m, ≤ Ra0.6 μ m, ≤ Ra0.4 μ m,
Mechanical seal	Single and double mechanical seals
Mechanical seal combination	See configuration table
Inlet/Outlet connection	Thread, clamp, flange, Aseptic flange
Certification	 CE  EC 1935/2004

Technical Advantages

- Maintenance disassembly and installation can be completed without professional staff and special tools.
- Initial use of installation debugging, the motor will not be damaged even if after a short reverse rotation.
- The impeller and shaft are connected by the key groove.

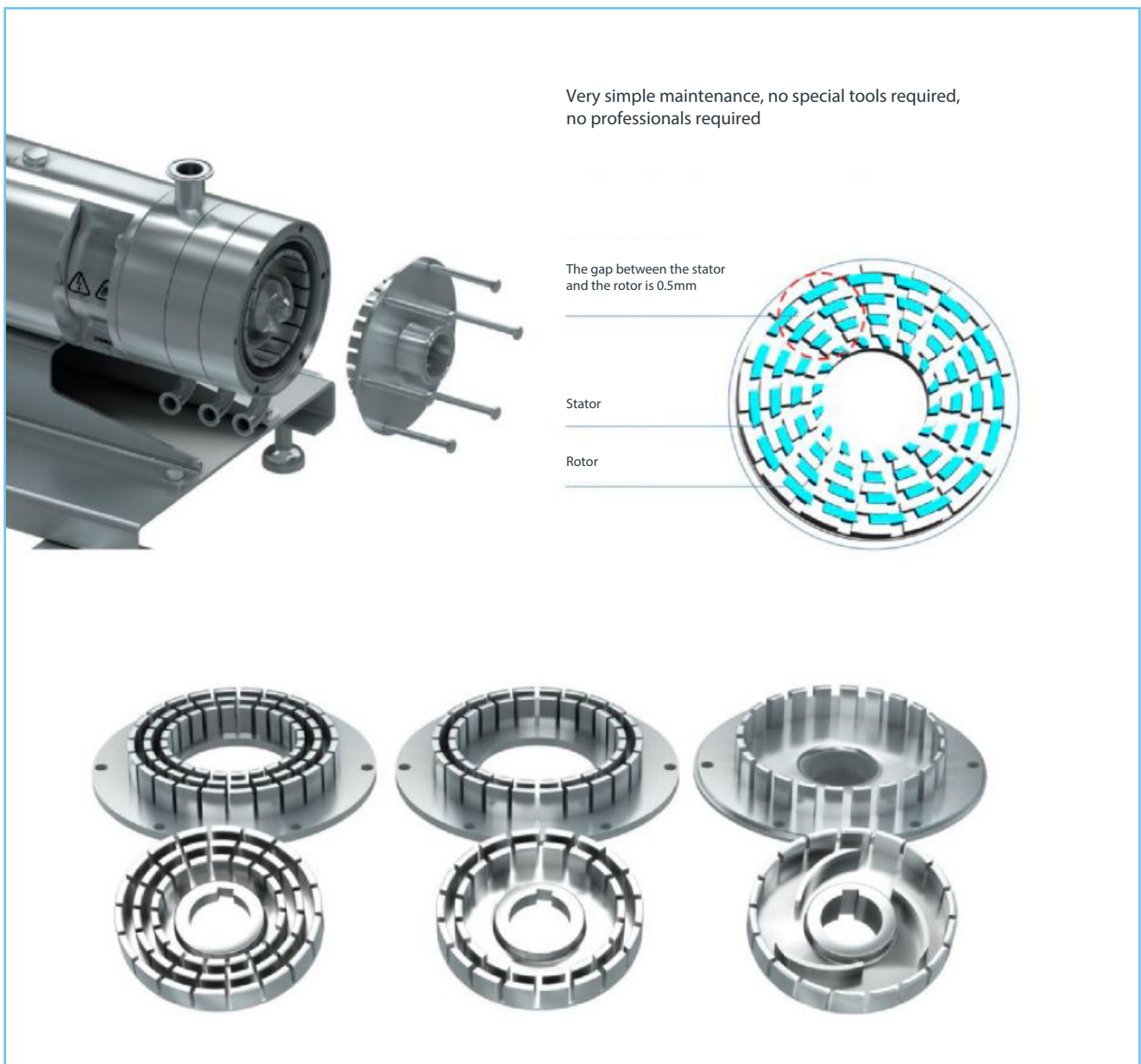



Working Schematic Diagram



Bottom drain valve



Single-stage discharge or sampling

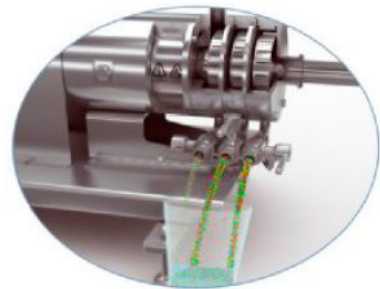

All discharge or sampling



First stage stators and rotors

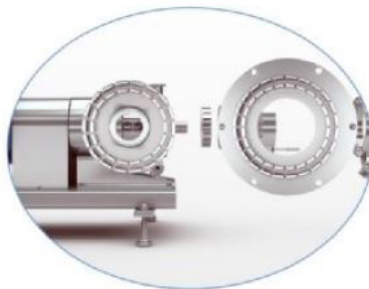

Second stage stators and rotors

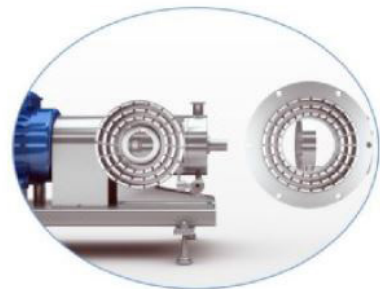

Thrid stage stators and rotors

Typical applications



Food & beverage

Juice, jam, ice cream, dairy products, food additives, tea drinks, chocolate, soymilk, essence



Daily chemical

Liquid detergent, liquid soap, facial cleanser, emulsified silicone oil, fragrance compound, skin care product, cosmetics



Bio-pharmaceutical

Injection, antibiotic, medicine emulsion, medicine emulsifiable paste, health care products, microcapsule emulsification, cell tissue smash, etc



Papermaking

Paper pulp, padding, dry strength agent, wet strength agent, sizing agent, retention and drainage aid, antifoaming agents, coating, water treatment chemicals, etc



Petrochemical industry

Lubricant, heavy oil emulsification, diesel oil emulsification, modified asphalt, catalyzer, wax emulsion, etc. Homogeneous and emulsified media required for various industrial petrochemical.



Fine chemical engineering

Pigment, dyestuff, plastic additive, textile assistant, adhesive, resin emulsification, hot melt adhesive, sealant, glue, sizing agent, finishing agent, surfactant, dye leveller, carbon black dispersion, anti-sticking agent, textile finishing agent, brightener, leather auxiliaries, pigment paste, and emulsifying, homogenizing and mixing materials for various chemical industries.



Coating & ink

Printing ink, oil paint, emulsion paint, coating, nanopaint, photocurable coating, coating adhesive, carbon black dispersion, glaze, bentonite, etc



Pesticide

Agricultural medicine medium for emulsification and homogenization of various pesticides such as insecticide squeezing, herbicide, pesticide emulsifiable concentrate, fertilizer and pesticide auxiliaries.

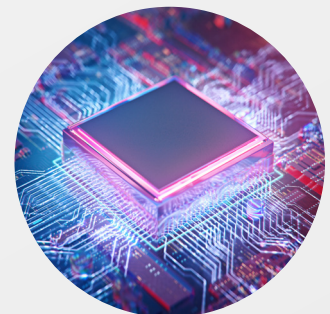

Semiconductor

Dispersion & depolymerization of nanometer materials, etc



Mechanical Seal Features

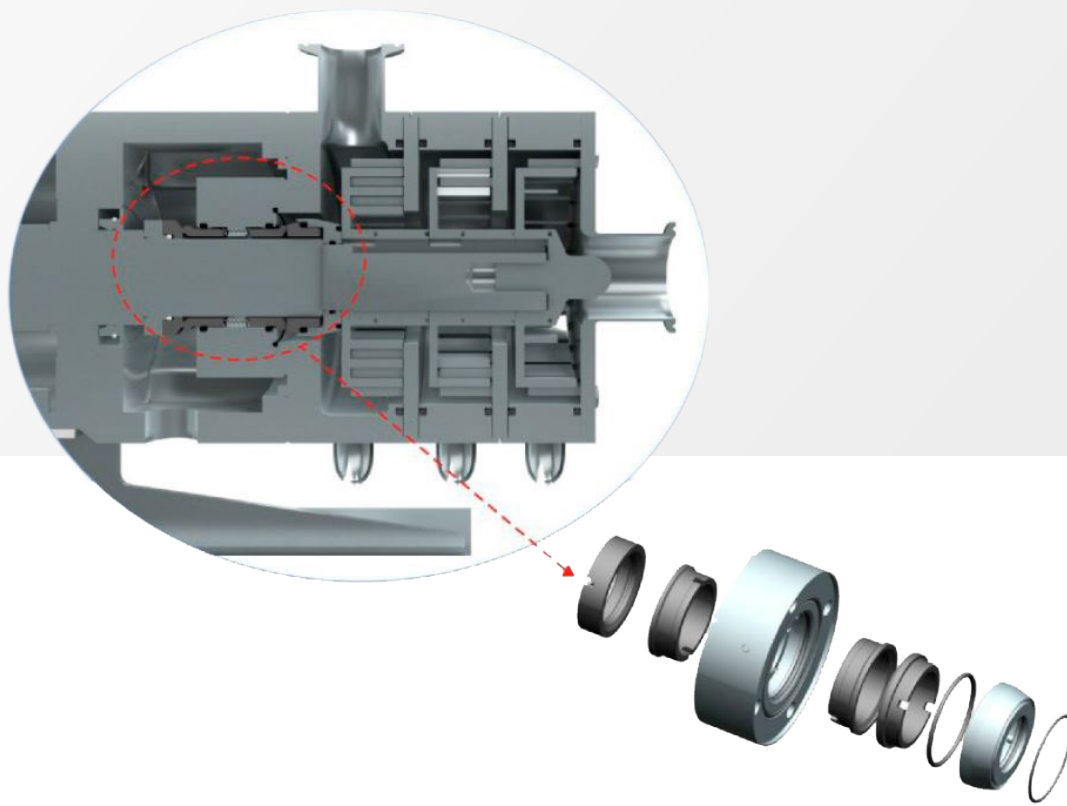

The mechanical seal is designed with pressure balance and super long working life, can be disassembled and maintained easily without special tools. The sanitary purity is according to CE and EC 1935/2004 certifications, and has lots of configuration.

Mechanical Seal Configuration	
Standard	Optional
1. SIC/C/EPDM	2. SIC/C/FKM 3. SIC/C/HNBR 4. SIC/SIC/EPDM 5. SIC/SIC/FKM 6. SIC/ SIC/HNBR 7. TC/TC/EPDM 8. TC/TC/FKM 9. TC/TC/HNBR

Note: The above configuration is suitable for double mechanical seal

Spare parts component

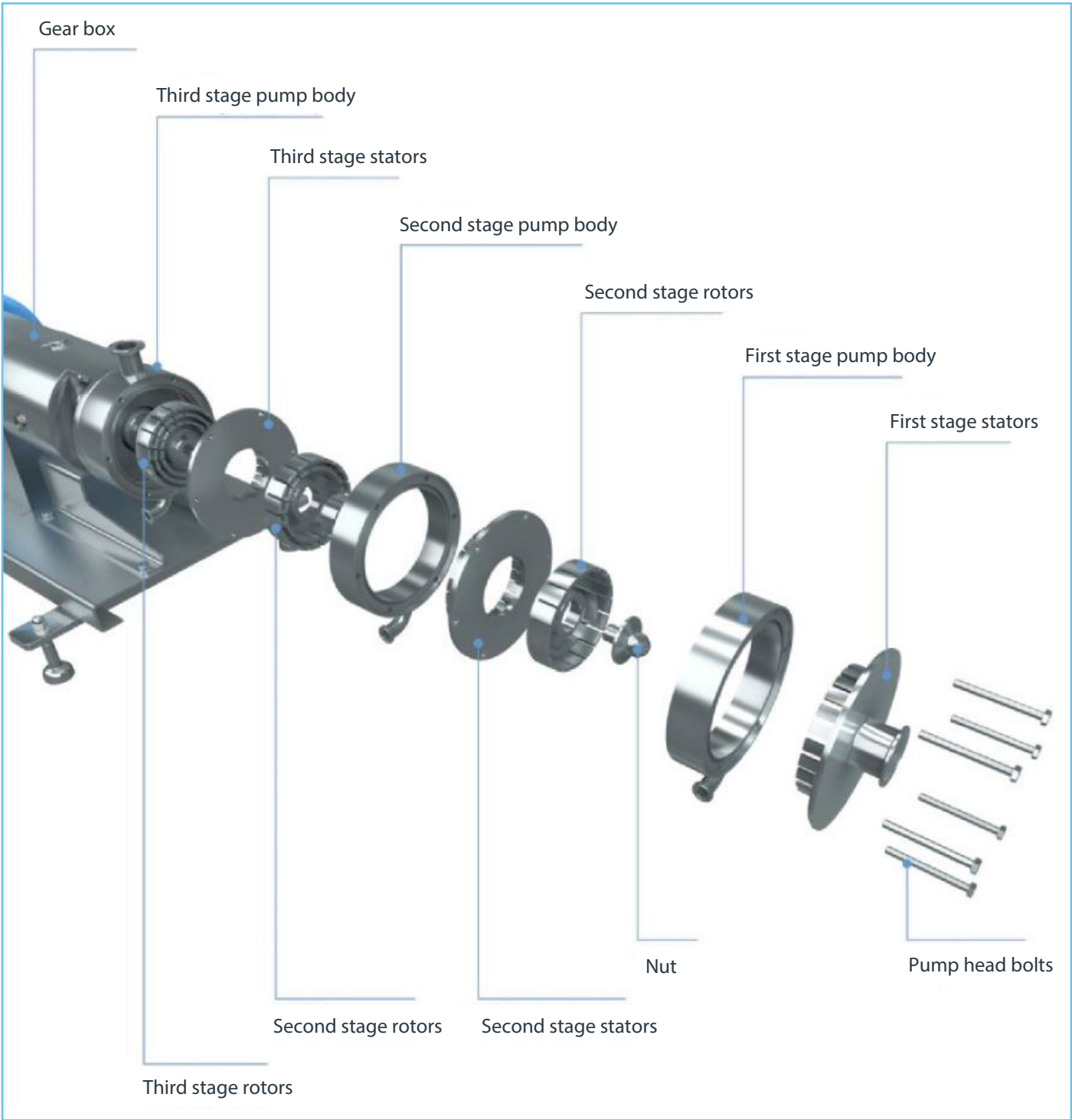



Model Instruction

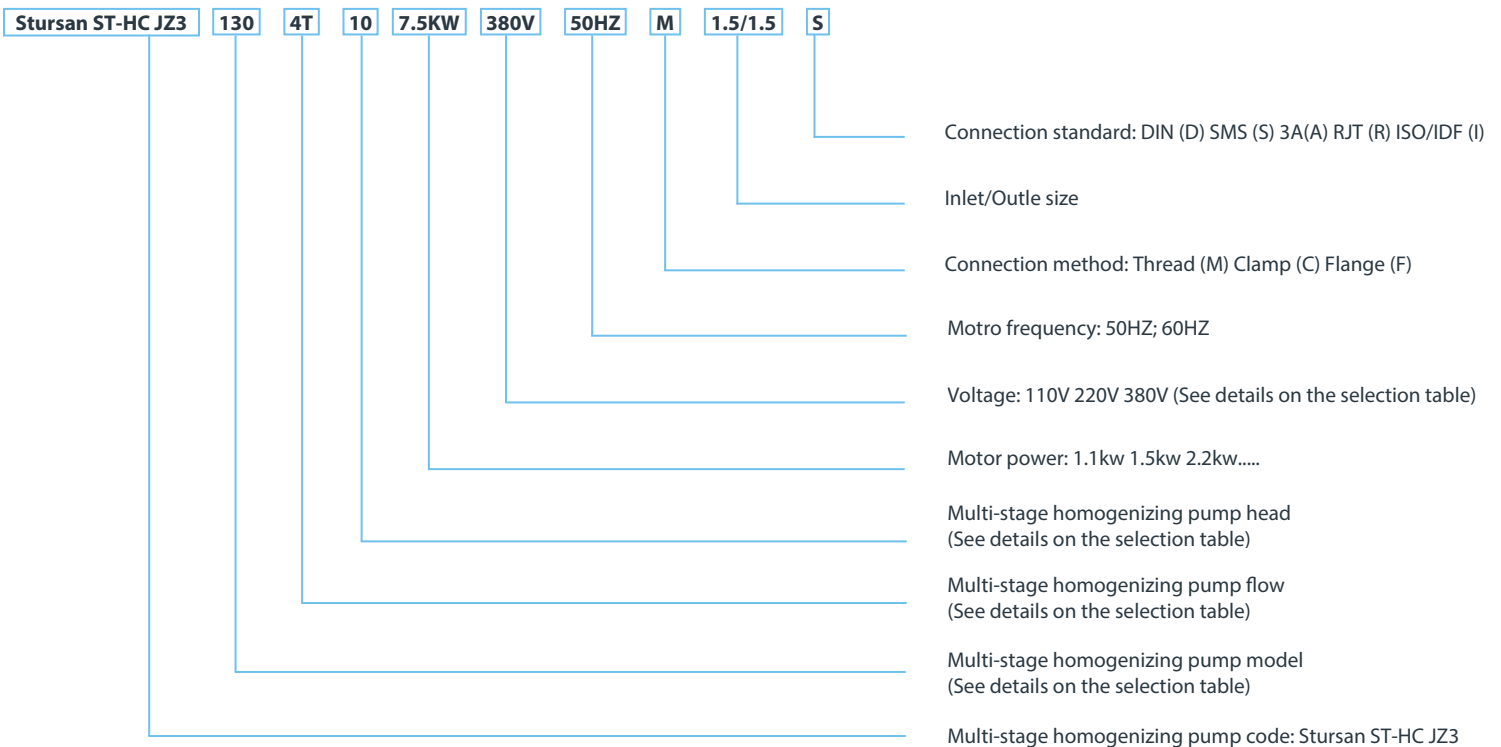
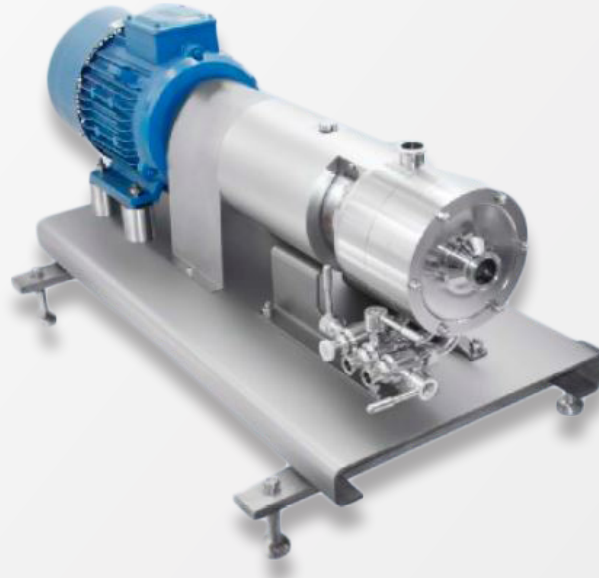

For example: Stursan ST-HC JZ3-130-4T-10-7.5KW-380V-50HZ-M-1.5"/1.5"-S

Selection table

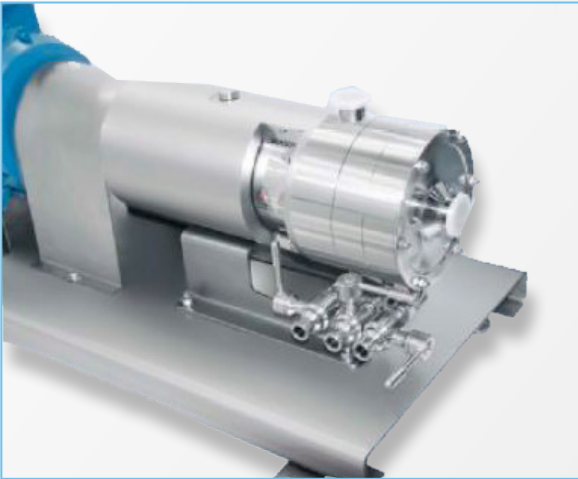

Model	Power (kw)	Flow (m ³ /h)	Outlet pressure (bar)	Rotate speed (r/min)	Inlet	Outlet	Weight (kg)
Stursansan ST-HC JZ3-130	7.5	4.0	1.0	2900	1.5"- DN40	1.5"- 1.1/4"	139.5
	11		2.0	2900			183.5
Stursansan ST-HC JZ3-150	11	6.0	2.0	2900	2"- DN50	1.5"- DN40	189.8
	15		2.0	2900			202.8
Stursan ST-HC JZ3-170	15	12.0	2.0	2900	2"- 2.5"	2"- DN50	237.2
	18.5		4.0	2900			245.2
Stursan ST-HC JZ3-190	22	20.0	2.0	2900	3"- DN65	2"- 2.5"	298.9
	30		5.0	2900			346.9
Stursan ST-HC JZ3-210	45	30.0	2.0	2900	3"- DN80	2.5"- DN65	433
	55		5.0	2900			494
Stursan ST-HC JZ3-240	75	50.0	2.0	2900	4"- DN100	3"- DN80	806
	90		5.0	2900			846



Data sheet

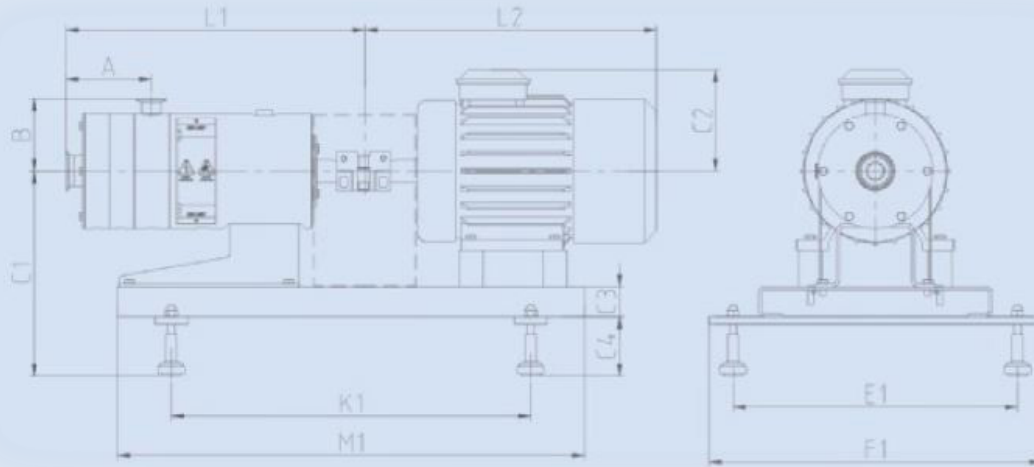

Model	Power (kw)	Inlet	Outlet	C1	C3	C4	E1	F1	K1	M1	L1	L2	C2	A (*)	B (*)
Stursansan ST-HC JZ3-130	7.5	1.5" - DN40	1.5" - 1.1/4"	342	50	99	475	555	600	780	577	531	169	144	124
	11			342	50	99	475	555	600	780	577	597	253	144	124
Stursan ST-HC JZ3-150	11	2" - DN50	1.5" - DN40	334	50	99	475	555	600	780	540	597	253	177	139
	15			334	50	99	475	555	600	780	540	597	253	177	139
Stursan ST-HC JZ3-170	15	2" - 2.5"	2" - DN50	377	50	99	545	625	920	1100	590	597	253	226	155
	18.5			377	50	99	545	625	920	1100	590	597	253	226	155
Stursan ST-HC JZ3-190	22	3" - DN65	2" - 2.5"	395	50	99	545	625	920	1100	647	693	254	283	169
	30			395	50	99	545	625	920	1100	647	738	273	283	169
Stursan ST-HC JZ3-210	45	3" - DN80	2.5" - DN65	415	50	99	545	625	920	1100	700	834	314	323	184
	55			415	50	99	545	625	920	1100	700	892	335	323	184
Stursan ST-HC JZ3-240	75	4" - DN100	3" - DN80	440	50	99	695	775	1420	1600	790	992	495	413	210
	90			440	50	99	695	775	1420	1600	790	1062	495	413	210

Note: The relevant dimensions of the above data diagrams are not regarded as the final basis of the actual object. Stursan reserves the right to update the data without further notice.

Note: The dimensions with (*A) and (*B) are based on the size of the clamp connection. Flange size will be different if use other connection, please contact us for details.



Stursan.com

Emulsifying homogenizing pump series

10.2020 / Revisión 1

 STURSAN



 sturhygienic@stursan.com

 www.stursan.com