

Operating Manual Self-Priming Pumps



Type ST-HC-CIP-U/L





Catalogue

Pages

1 Summarize	- 4 -
1.1. About the User Manual	
1.2. Safety warning symbol	
1.3. Delivery content	
2 Security announcements	- 4-5 -
2.1. Basic security instructions	
2.2. Application range	
2.3. Common error operation	
2.4. Safety instruction for pump	
2.5. Nameplate	
2.6. Warning sign	
2.7. Waste treatment	
3 Structural features and working principles	- 6-7 -
3.1. Basic structure	
3.2. General configuration	
3.3. Model	
3.4. Model Description	
4 Transportation	- 7-8 -
5 Storage	- 8 -
5.1. Storage environment of the pump	
5.2. Restart to use	
6 Installation and use procedures	- 8-10 -
6.1. Installation safety instructions	
6.2. Precautions for pump installation	
6.3. Reduce noise and vibration	
6.4. Installation method	
6.5. Pipeline installation	
6.6. Electrical installation	
6.7. Water flush pipeline connection	
6.8. Cleaning	

Catalogue

pages

7	Running Operation	- 10-11 -
	7.1. Safety Instruction	
	7.2. Advance Preparation	
	7.3. Observe operation	
	7.4. Finish operation	
8	Cleaning	- 11 -
	8.1. CIP cleaning	
	8.2. SIP cleaning	
9	Common Fault and Removal	- 11 -
10	Maintenance	- 11-14 -
	10.1. Security instructions	
	10.2. Check rinse solution (double mechanical seal)	
	10.3. Replace mechanical seal	
	10.4. Disassembly of Centrifugal pump	
	10.5. Centrifugal pump head assembly	
11	Appendix	- 15-18 -
	11.1. Torque table for bolts and nuts	
	11.2. Common operating problem and troubleshooting	
	11.3. Exploded view and parts list	



1 Summarize

1.1. About the User Manual

Manual is composed of two parts, the text part and the appendix. The text part of the manual contains the general knowledge of the storage, installation, operation and maintenance of Pump. The appendix of the manual includes the special debugging of this pump and the name of spare parts.

1.2. Safety warning symbol



Warning symbol
Warning you of personal danger



Warning symbol
Warning of electrical hazard



Warning symbol
Warning of falling objects



Warning symbol
Warning the danger of mechanical injury



Attention symbol
Ensure security responsibilities



Warning symbol
Warning risk of mechanical damage

1.3. Delivery content

- Package attached list
- Contain motor (Option to provide pump head only)
- Pump instruction
- Motor instruction

2 Safety precautions

2.1. Basic safety instructions



Before using the pump, please read this operation manual carefully and save the manual in the pump working area for easy viewing.
All pump-related work require careful operation by experienced person

2.2. Application range

- ST-HC-CIP-U/L pumps are commonly used in food, pharmaceutical, biopharmaceutical, daily chemical and CIP applications
- ST-HC-CIP-U/L pumps are available in different operating temperature and pressure range depending on different design and model.
- ST-HC-CIP-U/L pumps need choose suitable mechanical seal material according to different media

2.3. Common error operation



Improper media may cause damage to the pump
Impurities present in the media may cause the pump to get stuck or even be damaged

2.4. Safety instruction for pump



- Running without medium

Pump is strictly prohibited to run without medium.

If using double mechanical seal , it is allowed to run without medium for a short time.

If using single mechanical seal , short time dry rotation may also cause damage to the mechanical seal.



- Pump surface high temperature

It will cause high temperature after pump running , do not touch , it will hurt you Check the surface temperature before touching pump.

2.5. Name plate

 Danger electric shock	STURSAN ST-HC-CIP-U-10-M-D	
	Serial No: <input type="text"/>	Date: <input type="text"/>
 Be careful with hand	<input type="text"/> :m ³ /h <input type="text"/> :M	<input type="text"/> :kW <input type="text"/> :Inlet/Outlet
	 www.stursan.com	

2.6. Warning sign

Please set warning sign in the pump working area

2.7. Waste treatment



Please follow the relevant regulations to dispose of the disassembled waste



3 Structural feature and working principle

3.1. Basic structure

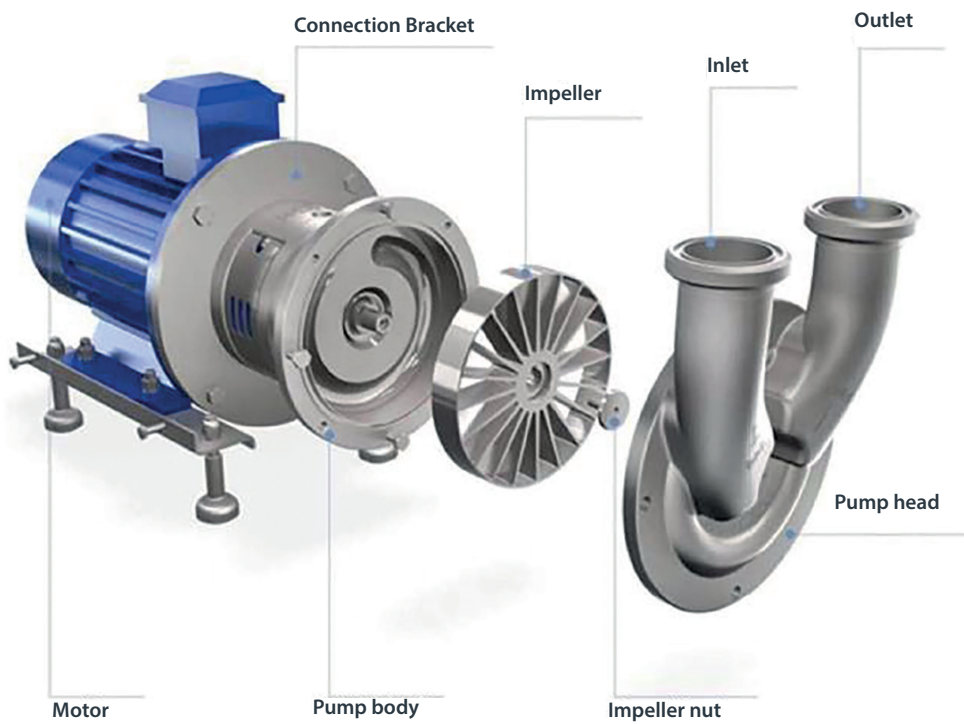

3.2. General configuration

- Single mechanical or double mechanical seal (double mechanical seal recommended)
- L type U type pump head (Select according to demand)

3.3. Model

ST-HC-CIP-L Series	ST-HC-CIP-U Series
ST-HC-CIP-L-05	\
ST-HC-CIP-L-10	ST-HC-CIP-U-10
ST-HC-CIP-L-20	ST-HC-CIP-U-20
ST-HC-CIP-L-30	ST-HC-CIP-U-30

3.4. Model Description

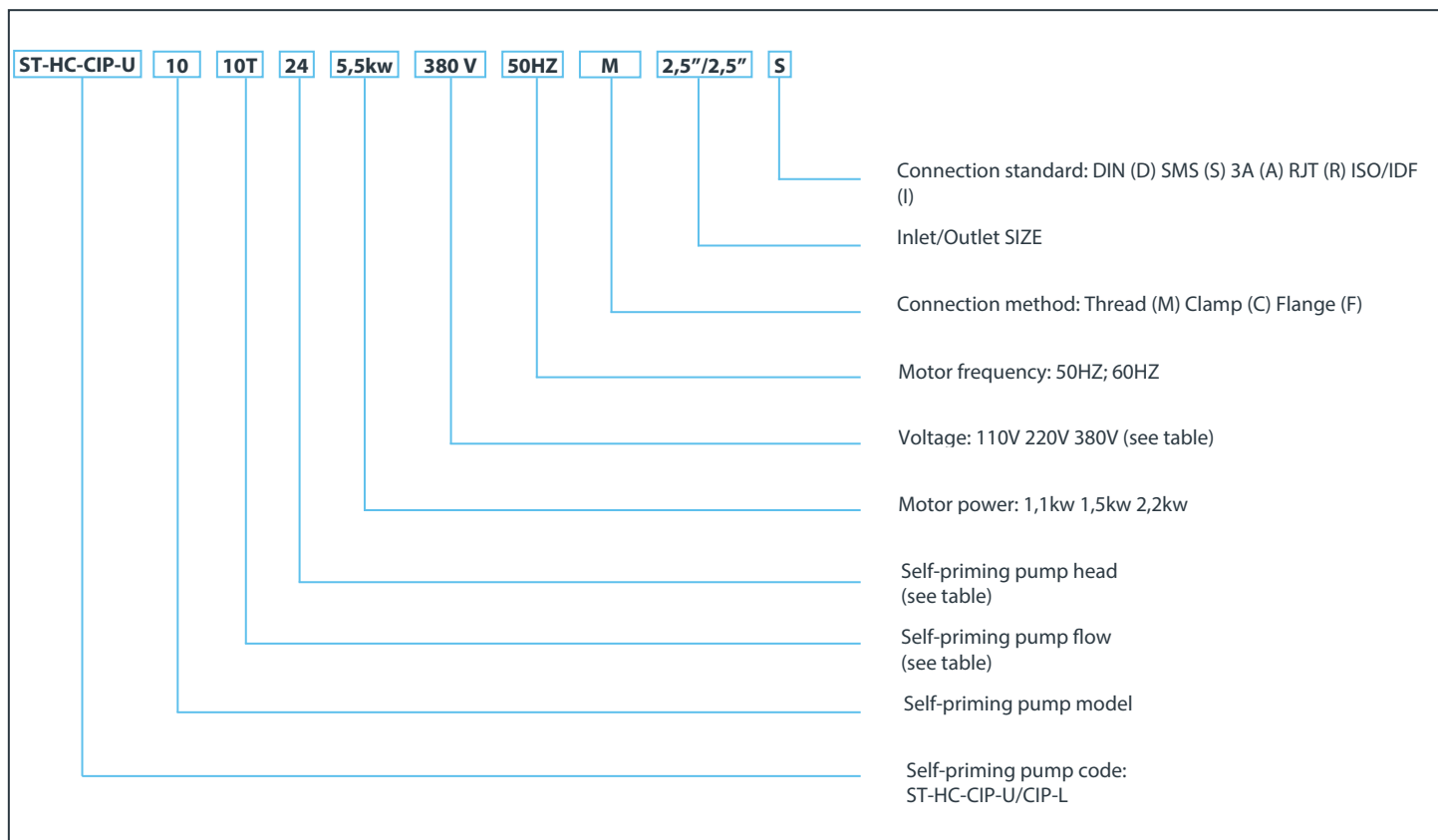

For example: ST-HC-CIP-U-10-10T-24-5,5KW-380V-50HZ-M-2,5"/2,5"-S

4 Transportation

- Trained person are required to transport the pump
The complete set pump can be handled by forklift or crane

4.1. Safety instructions

- Be careful to drop or unfixed parts that can cause severe abrasions.
- Do not remove the inlet and outlet end caps of the pump until the piping is connected.

4.2. Forklift transportation instructions



- Pay attention to parts falling, which may cause serious injury and bruises on your hands and feet. To prevent rollover during transportation, use a conveyor belt or bolt to fix the plate



4.3. Crane transportation instructions



- «**Warning**», pay attention to parts falling, which may cause serious injury, bruises and even death. To prevent falling during transportation, use a suitable lifting tool.
- Please make sure that the crane and the rope have enough bearing and strength.
- Make sure nobody stay under pump

5 Store

5.1. Storage environment of the pump



- The pump shall be stored according to the following procedures:
 1. Drain the pump medium and keep it dry. Store it in a dry environment
 2. Storage temperature should not be too high or too low, suitable for storing temperature is 20 °C to 25 °C (normal temperature)
 3. The storage environment shall be ventilated and dust-free
 4. All parts of the pump are required to rotate regularly (three months)

5.2. Restart to use

- After storage, please check the mechanical seal before restart to use.

6 Installation and use procedures

6.1. Installation safety instructions



- Make sure that each part is fixed during installation, falling parts may cause damage to the pump, as well as injury to personnel
- Please wear labor protection shoes when installing
- Fix bolt according to the specified torque, please check 11.1 (Bolt Fixed Torque Table)
- Use a torque wrench

6.2. Precautions for pump installation



- Confirm the installation environment of the pump, explosion-proof pump should be used in the explosion-proof environment
- The environment must be dust-free
- Working environment temperature at -20°C to 40°C
- The installation platform must be strong enough to support the whole pump
- The installation platform must be horizontal
- Sufficient maintenance space must be guaranteed
- Ensure the air circulation of the installation environment and promote the heat dissipation of the motor

6.3. Reduce noise and vibration

6.3.1 Main measures

- Operate in optimum working conditions to avoid cavitation
- Avoid resonance of inlet and outlet pipeline
- Fix inlet and outlet pipelines

6.3.2 Auxiliary measures

- Isolation measures can be used to isolate noise, such as sound insulation coverage, space isolation, etc

6.4. Installation method

- Use base mounting to install the pump ,and the pump is mounted on a fixed mounting platform
- Use base mounting to install (with adjustable support foot), the height of the support foot can be adjusted freely to ensure the stable installation of the pump

6.5. Pipeline installation

- Reduce pipe resistance as much as possible and avoid to use unnecessary elbows and valves
- When designing piping connection, try to avoid causing pressure loss and avoid cavitation caused by inhalation end
- The inlet and outlet control valves should be as close as possible to the inlet and outlet end
- Inhalation end pipeline should be as short as possible
- The inlet end pipeline should be installed horizontally to reduce the possibility of residual air in the pipeline
- Design pipeline reasonably according to pressure, temperature and medium characteristics
- Avoid stress from pipes to pumps (pipes must be supported independently)

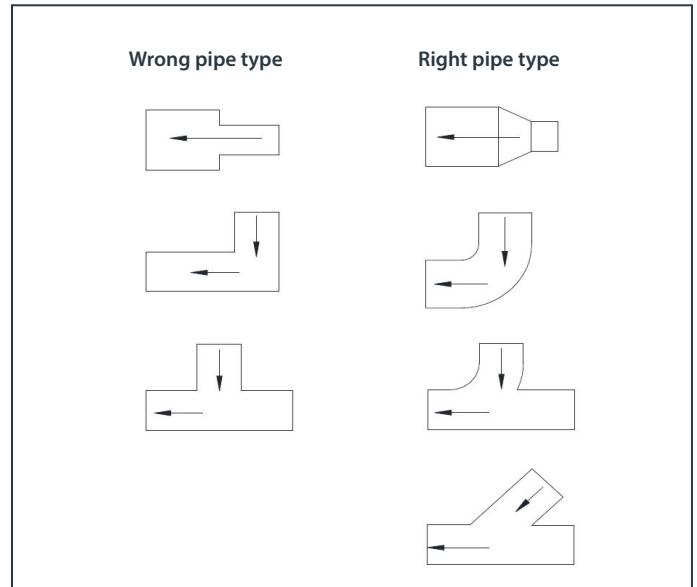

6.6. Electric Power Installation



- «**Warning**» Attention should be paid to using ground wire to connect pumps to eliminate static electricity
- Electrical connections need to be completed by qualified electrical engineers
 1. Check motor nameplate to confirm rated power, rated voltage and wiring mode
 2. Follow the wiring diagram in the Motor junction box to connect the electricity
 3. Click start motor with less than 1 second and check motor rotation direction
 4. Rewiring is required if the rotation direction is wrong.

Attached image, correct rotation direction of motor

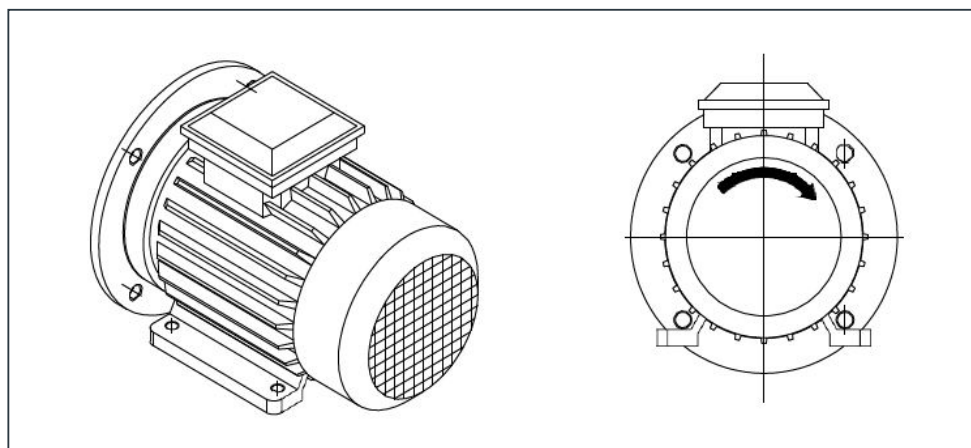



6.7 Water Flushing Pipeline Connection (Double Machine Seal)

- Pumps with double mechanical seals must be connected to water flushing lines and supplied with cooling water
- It is recommended that the flushing water should be entered from below and discharged from the top

OD of Hose coupling connection	Inlet and outlet thread connection
6 mm	G1/8

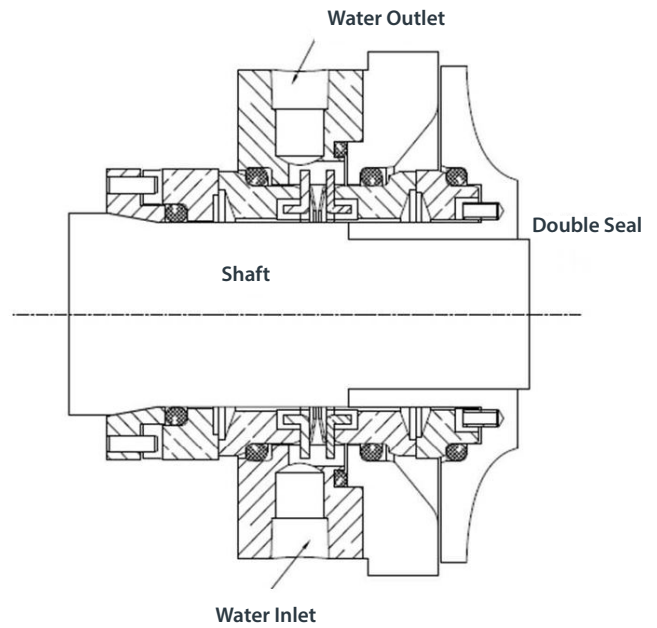

6.8. Cleaning



1. Before cleaning, make sure there is no impurities in the pump chamber and pipeline
2. Confirm that the pump is in the stop state
3. Connecting the pipeline
4. Before the first use, please thoroughly clean the pump and pipeline

7 Running Operation

7.1. Safety Instruction



- Please confirm outlet valve has been opened when turning on pump and in operation. In order to avoid overhigh outlet pressure, it could be added with bypass line or safety valve etc. protective measures

- Please confirm inlet valve has been opened when turning on pump. If inlet valve is closed, will be occurred with idling, and mechanical seal will be damaged



- Please confirm pump chamber has been full filled with liquid before turning on pump. If without liquid in pump chamber, will be occurred with idling, and mechanical seal will be damaged

7.2. Advance Preparation



1. Double mechanical seal: to confirm cooling water has been connected .
Note: cooling water temperature <70 °C; to adjust the pressure of wash water <1bar
2. To open inlet valve
3. To open outlet valve
4. Waiting for a while, to confirm the pump chamber and inlet pipeline has been full filled with liquid
5. Start motor

7.3. Observe Operation

Safety Instruction in pump operation:

- Pump was stuck or damaged: there might be with impurity in your media
- It's prohibited to close outlet valve in pump operation, if not, will be caused with moment overhigh pressure and damage on pump
- It's prohibited to close inlet valve in pump operation, if not, will be caused with cavitation and idling and damage on mechanical seal

7.4. Finish operation

1. To turn off motor
2. To close inlet valve, to avoid idling in next operation
3. To close outlet valve

8 Cleaning

8.1. CIP Cleaning

- ST-HC-CIP-U/L pumps is supported with CIP cleaning.

8.2. SIP Cleaning



- **Note:** Do not turn on pump in SIP sterilization, idling will be caused with damage on mechanical seal
- Allow with max. steam temperature 145°C

9 Common Fault and Removal

- See appendix 11.2 (Common Fault and Removal)

10 Maintenance

10.1 .Safety Instruction



- To confirm the motor has been turned off and powered off when touch pump
- Please wear safety shoes, to avoid unnecessary damage
- To close inlet and outlet valve
- Double mechanical seal pump: to switch off wash water
- To fully discharge liquid in pump chamber before separating pump

10.2. To inspect wash water (double mechanical seal)

If choose double mechanical seal pump:

- To inspect wash water pressure <1bar.
- To confirm wash water temperature <70 °C

10.3. To replace mechanical seal

Need to replace mechanical seal in the following situation:

- When conveying media, with leakage
- When conveying media, with leakage of wash water
- When conveying media, wash water was into conveying liquid

Please refer to the chapter of disassembly and installation of pump head - mechanical seal, when to replace.



10.4 Self-priming pump head disassemble(ex.ST-HC-CIP-U Self-priming pump)

10.4.1 Disassemble pump head and impeller

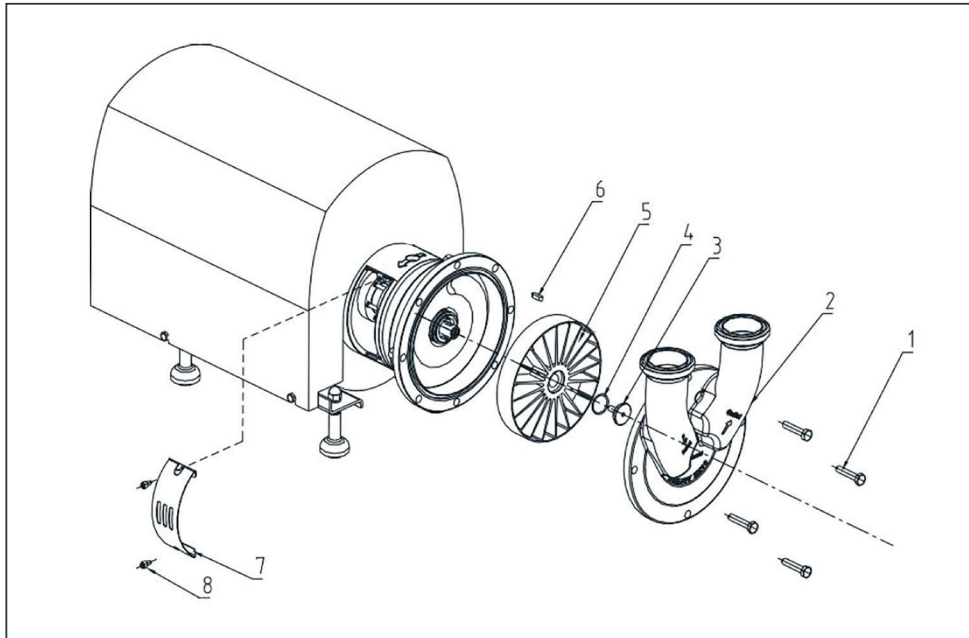

1. Disassemble head cover bolts (part 1)
2. Disassemble pump head cover (part 2)
3. Disassemble side signs (part 7) bolt (part 8)
4. Fixed the pump shaft with tools, rotate counterclockwise, and remove the impeller nut (part 3)
5. Take down impeller nut O-ring (part 4)
6. Disassemble impeller (part 5)
7. Take down pump shaft on the flat key (part 6)

10.4.2 Mechanical seal disassembly

Mechanical seals are available in two configurations: single and double mechanical seals

Single mechanical seal disassemble procedure:

1. Take out the single mechanical seal assembly as shown on the right (part S1, S2)

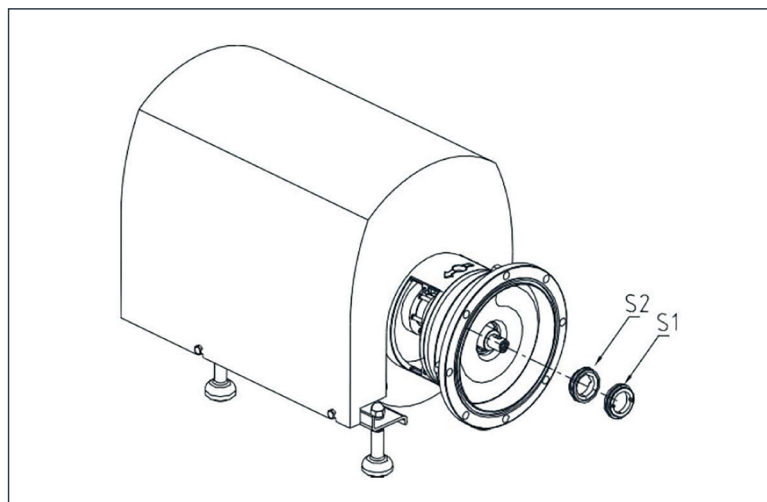

Double mechanical seal disassemble procedure

1. Take out the inner sealing ring, static ring, as shown on the right (Part D1 D2)
2. Take down back cover (part 9)
3. Take down bolt (part D8), water seal (part D4), spring components (part D3)
4. Take down the external seal static ring (part D5), moving ring (part D6) and support (part D7) successively.

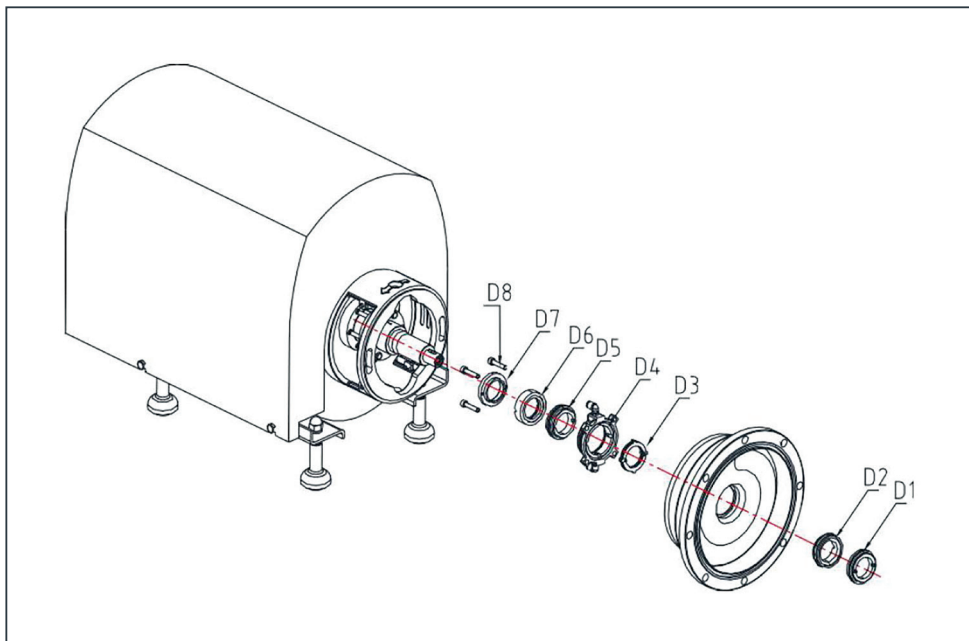

Attached pictures (structure sketch of single and double mechanical seal)

Single Seal

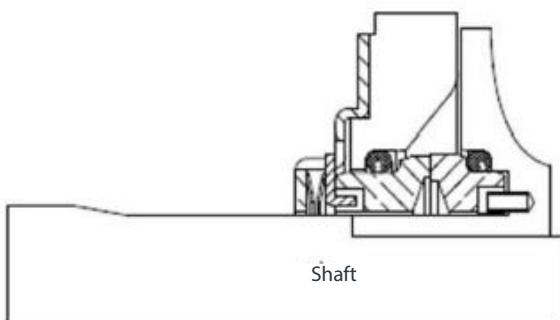

Double Seal

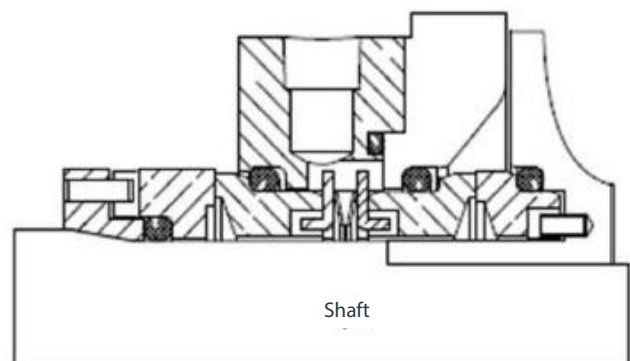



10.5. Self-priming pump head assembly

Preparing before assembly

- Cleaning the component
- If there is some part to replace
- Please note that it should be assembled in a clean environment while the mechanical seal is easy to be damaged
- Please use water or lubricating grease to clean the mechanical seal before assembly
- Please do not touch after cleaning

10.5.1 Adjust the clearance between impeller and back cover

1. Install the pump shaft assembly into the motor shaft, pretighten the sleeve screw, but do not tighten it completely.
2. Mount the connecting bracket, back cover, impeller and impeller nut successively. Adjust clearance "S" between impeller and rear cover S (see the table)

Model	$S \pm 0.1\text{mm}$
CIP-L-05	0,4 mm
ST-HC-CIP-U/L-10	0,4 mm
ST-HC-CIP-U/L-20	0,35 mm
ST-HC-CIP-U/L-30	0,65 mm

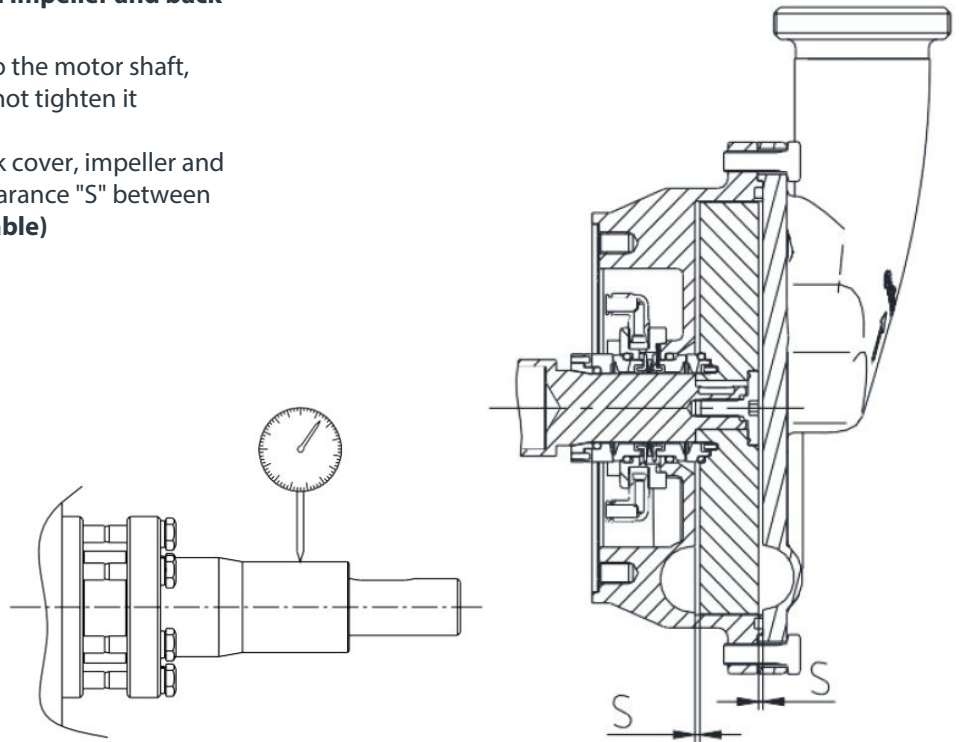

3. Take down the impeller nut, impeller, back cover, connecting bracket, and lock the fastening screw.
3. Use dial indicator to check pump shaft circular runout, which should be controlled below 0.05mm.

10.5.2 Install bracket and back cover

1. Install connection bracket
2. Machine seal press plate, machine seal spring into the back cover
3. Install back cover

10.5.3 Mechanical seal installation

Reverse assembly according to the disassembly steps of mechanical seal (refer to the schematic diagram of mechanical seal structure for mechanical seal structure)

10.5.4 Install impeller

1. Put the flat key into the pump shaft
2. Insert the impeller into the pump shaft
3. Install O - ring on impeller nut and tighten with 18NM.

10.5.5 Install pump front cover and bolts

1. Put O - ring into front cover sealing groove
2. Install Pump head cover
3. Tighten the front cover fixing nut and install torque. See "bolt tightening torque" in chapter 11.

11 Appendix

11.1. Bolt tightening torque

Set bolt and nut torque $\pm 15\%$ Materials grade A2-70

Nut/bolt	M6	M8	M10	M12	M16	M20
Tightening torque NM	7	18	36	63	143	262

11.2. Common fault and eliminating methods

Work Breakdown	Common cause of failure	Solution
No flow or unstable flow	Pump chamber is not filled with liquid	Filling of liquid
	Outlet valve is closed	Open outlet valve
	Inlet pipe is closed or blocked	Open inlet piping or wash
	Pump stuck	Clean the pump chamber and check if there is any foreign body entering
	Medium viscosity is too high to be inhaled	Contact Stursan
Flow and discharge too small	Model of the pump is too small	Contact Stursan
	Wrong direction of motor rotation	Adjust motor steering
	Suction pipe or pump suction end leakage	Check pipeline and repair
	Transport medium viscosity is too high, poor liquidity	Contact Stursan
	Too low speed (wrong voltage)	Check power supply voltage according to motor nameplate
Noise and vibration	Hard object in the pump chamber	Exclude foreign body
	Impeller scratches	Check impeller clearance and adjust
	Suction line resistance is too large	Increase inlet pipe diameter and shorten pipe length
	Pipe weight and pressure act directly on the pump	Add pipeline support to eliminate resonance
Sudden increase in shaft power	Too high viscosity of conveying medium	Contact Stursan
	Impeller scratches	Check impeller clearance and adjust
	Bearing or motor damage	Check and repair
Mechanical seal leakage	Damaged mechanical seal(wear)	Change mechanical seal
	Mechanical seal dry rotation, medium temperature is too high	Double mechanical seals are recommended
	Corrosion of mechanical seal material	Contact Stursan
	Flushing circulation line is blocked cause dry rotate	Check and repair

11.3. Vista en despiece y lista de piezas

Unmarked finished size	
Linear tolerance	
Length (mm) Tolerance (mm)	
<=6	±0.05
6-18	±0.10
18-63	±0.15
>=63	±0.20
Angle Tolerance	
Length (mm) Tolerance (mm)	
<=10	±30'
10-50	±20'
50-120	±15'
120-400	±10'
Tolerance of verticality	
Length (mm) Tolerance (mm)	
<=100	0.1
100-300	0.2
>=300	0.3
Blank size, Unfilled Polished	
Linear tolerance	
Length (mm) Distance (mm)	
<=6	±0.10
6-30	±0.15
30-120	±0.20
>=120	±0.30
Angle Tolerance	
Length (mm) Distance (mm)	
<=10	±1°
10-50	±30'
50-120	±15'
120-400	±10'
Straightness and Flatness	
Tolerance	
Length (mm) Distance (mm)	
<=10	0.05
10-50	0.10
50-120	0.20
120-400	0.30
Tolerance of Verticality	
Length (mm) Distance (mm)	
<=100	0.2
100-300	0.3
>=300	0.4
Tolerance of Symmetry	
All	0.5
Description	
The bore tolerance is +	
Shaft tolerance is -	
Customer number	
Customer version	
Customer number	
Old item number	

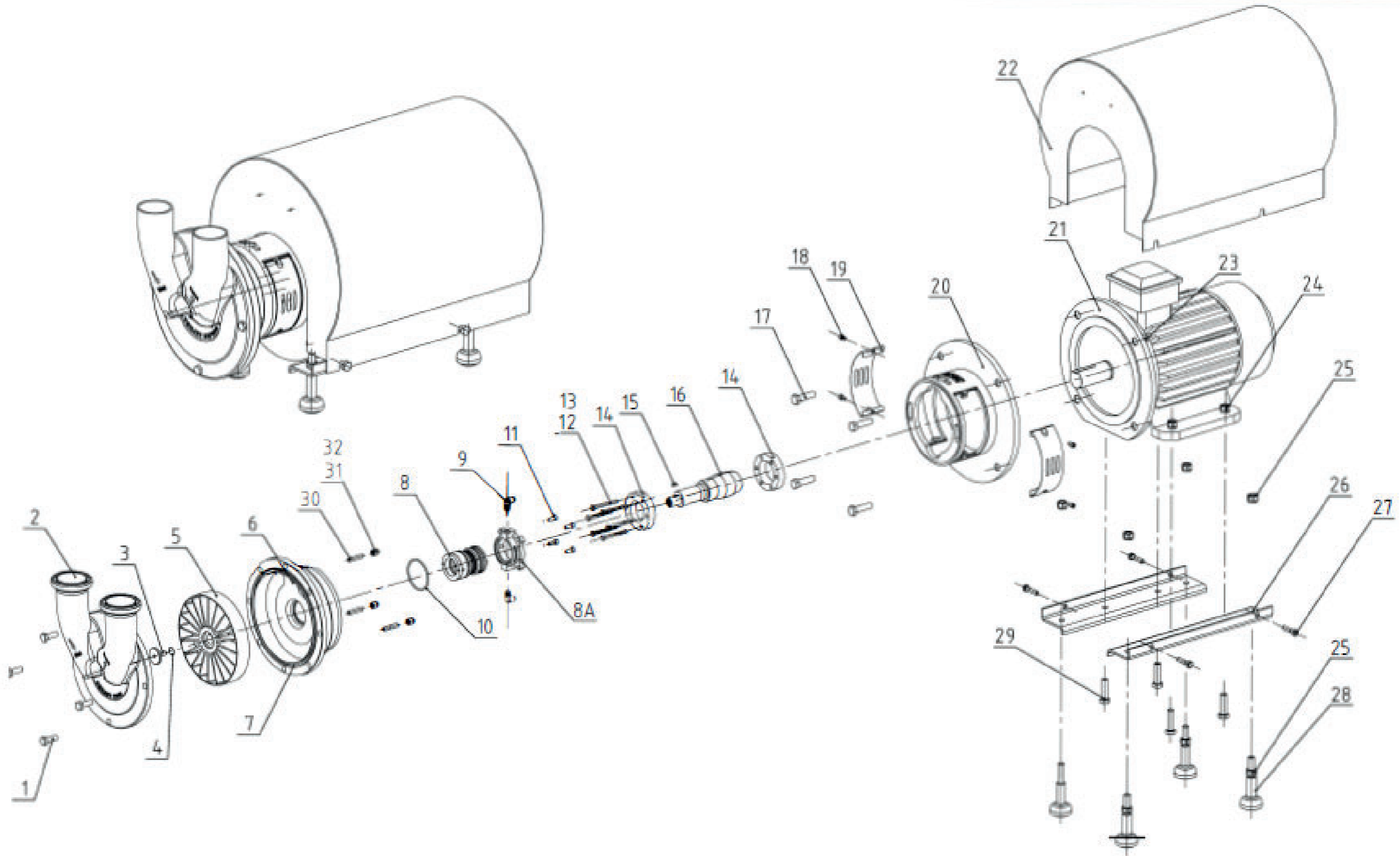

										
										ST-HC-CIPL 10-20 Exploded view of the self-priming pump
Brand	Number of places	Division	Change file number	Signature	Date (Year/month/day)					
Design			Art			Stage Marker		Weight	Proportion	
			Standardisation			S	T	P		
Revision					1 in total		1 in total		REV 01	
Date			Approve							

Unmarked finished size	
Linear tolerance	
Length (mm) Tolerance (mm)	
<=6	±0.05
6-18	±0.10
18-63	±0.15
>=63	±0.20
Angle Tolerance	
Length (mm) Tolerance (mm)	
<=10	±30'
10-50	±20'
50-120	±15'
120-400	±10'
Tolerance of verticality	
Length (mm) Tolerance (mm)	
<=100	0.1
100-300	0.2
>=300	0.3
Blank size, Unfilled Polished	
Linear tolerance	
Length (mm) Distance (mm)	
<=6	±0.10
6-30	±0.15
30-120	±0.20
>=120	±0.30
Angle Tolerance	
Length (mm) Distance (mm)	
<=10	±1°
10-50	±30'
50-120	±15'
120-400	±10'
Straightness and Flatness	
Tolerance	
Length (mm) Distance (mm)	
<=10	0.05
10-50	0.10
50-120	0.20
120-400	0.30
Tolerance of Verticality	
Length (mm) Distance (mm)	
<=100	0.2
100-300	0.3
>=300	0.4
Tolerance of Symmetry	
All	0.5
Description The bore tolerance is + Shaft tolerance is -	
Customer number	
Customer version	
Customer number	
Old item number	

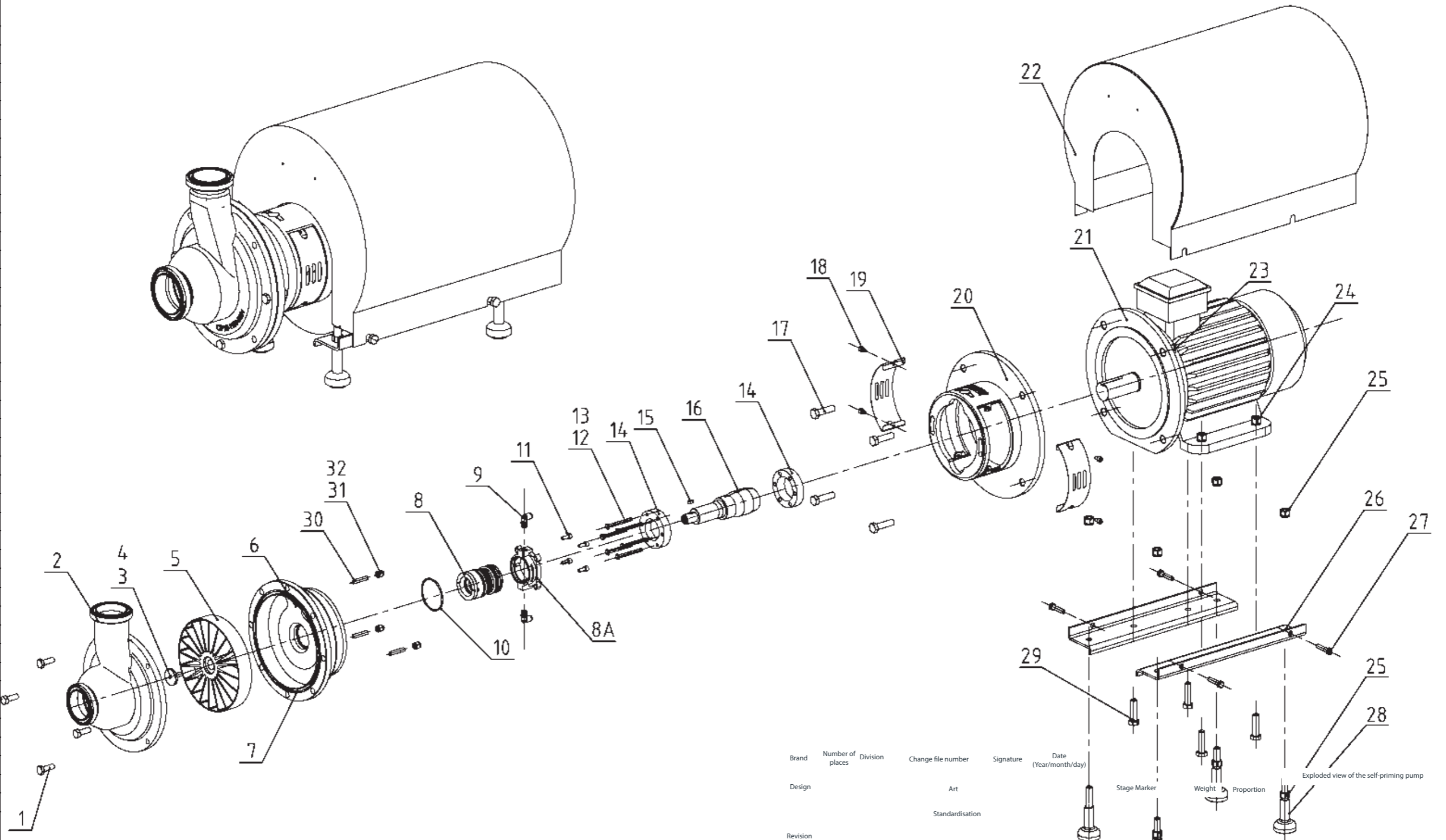

Brand	Number of places	Division	Change file number	Signature	Date (Year/month/day)	Stage Marker	Weight	Proportion	Exploded view of the self-priming pump
Design									
Revision									

Date		Approve				1 in total	1 in total	
Marca	Número de plazas	División	Cambiar el número de archivo	Firma	Fecha (Año/mes/día)			
Diseño			Arte			Marcador de escenario	Peso	Proporción
Revisión			Estandarización			S	T	P
Fecha			Aprobar			1 en total	1 en total	



ST-HC-CIPL 05-20
Vista de despiece de la bomba autocebante

REV 01



ST-HC-CIPU/CIPL pump explosion chart list(Rev. 01)

Code	Item	Specification				Qty	Material
		ST-HC-CIPL-05	ST-HC-CIPU/L-10	ST-HC-CIPU/L-20	ST-HC-CIPU/L-30		
1	Hexagon thread head bolt		GB5783 M10X30	GB5783 M10X30	GB5783 M10X30	4	A2-70
2	L type Pump head					1	304/316L
	U type Pump head					1	304/316L
3	Impeller Bolt					1	304
4	O ring	OD32X2	OD32X2	OD32X2	OD32X2	1	EPDM
5	Impeller					1	304/316L
6	Rear cover					1	304/316L
7	O ring	OD163X3.5	OD206X5	OD225X5.7	OD250X4	1	EPDM
8	Double mechanical seal	Stursan.R.PL32D				1	
	Single mechanical seal	Stursan.R.PL32S				1	
8A	Seal holder					1	304
9	G1/8 Nozzle	QSL-1/8-6				2	FEST O
10	O ring	OD60x2.5	OD60x2.5	OD60x2.5	OD60x2.5	1	EPDM
11	Hexagon socket cap screw	GB70.1 M6*16	GB70.1 M6*16	GB70.1 M6*16	GB70.1 M6*16	4	A2-70
12	Hexagon thread head bolt	GB5781 M6X50	GB5781 M6X50	GB5781 M6X60	GB5781 M6X80	6	A2-70
13	Spring washer	GB93 6	GB93 6	GB93 6	GB93 6	6	A2-70
14	Tight ring component					1	304
15	Flat key	6x12	6x12	6x12	6x12	1	304
16	Pump shaft					1	304
17	Hexagon thread head bolt	GB5783 M12X35	GB5783 M12X40	GB5783 M12X40	GB5783 M12X40	4	A2-70
18	Hexagon socket cap screw	GB70.1 M6*10	GB70.1 M6*10	GB70.1 M6*10	GB70.1 M6*10	4	A2-70
19	Portective cover					1	304
20	Bracket					1	304
21	Motor					1	304
22	Pump cover					1	304
23	Hex nut	GB6170 M12	GB6170 M12	GB6170 M12	GB6170 M12	4	A2-70
24	Hex nut	GB6170 M12	GB6170 M12	GB6170 M12	GB6170 M12	4	A2-70
25	Hex nut	GB6170 M12	GB6170 M12	GB6170 M12	GB6170 M12	4	A2-70
26	Under-chassis					2	304
27	Hexagon thread head bolt	GB5783 M8X35	GB5783 M8X35	GB5783 M8X35	GB5783 M8X35	4	A2-70
28	Under-chassis bolt					4	304
29	Hexagon thread head bolt	GB5783 M12X45	GB5783 M12X45	GB5783 M12X45	GB5783 M12X45	4	A2-70
30	Set screw	GB/T77 M8X30				3	A2-70
31	Spring washer	GB/T93 8				3	A2-70
32	Cap nut	GB/T802 M8				3	A2-70

Note:

- part 30, part 31, part 32 only use in the size ST-HC-CIPL-05.
- part 8A, part 9, part 10 only use with Double mechanical seal.



 sturhygienic@stursan.com

 www.stursan.com